

Fork Type Stacker PF-A

- ◆ Low profile forks can lift pallet easily.
- ◆ No-marking castor as standard.
- ◆ Conforms to EN 1757-1.

Manual

- ◆ Ladder as option.

Electric

- ◆ Easier and faster lifting operation.
- ◆ High quality hydraulic motor made in Italy.
- ◆ Service free battery.
- ◆ Option platform available.



PF Series Fixed Fork

Option Platform
Model: LP10, LP20



Option-Polar with bearing

PF-A

Model (Fixed Fork)		PF2085A	PF2120A	PF4085A	PF4120A	PF4150A
Capacity	(kg)	200	200	400	400	400
Max. Fork Height	(mm)	850	1200	850	1200	1500
Min. Fork Height	(mm)	85	85	85	85	85
Fork Length	(mm)	600	600	650	650	650
Fixed Fork Width	(mm)	500	500	550	550	550
Load Roller	(mm)	Ø75	Ø75	Ø75	Ø75	Ø75
Steering Wheel	(mm)	Ø125	Ø125	Ø125	Ø125	Ø125
Pump Strokes to Max. Height		19	26	35	50	63
Overall Height	(mm)	1080	1435	1060	1410	1710
Overall Width	(mm)	560	560	590	590	590
Overall Length	(mm)	1000	960	1040	1040	1040
Net Weight	(kg)	55	62	70	76	82
Option Platform		LP10	LP10	LP20	LP20	LP20

Fork Type Stacker PJ-A

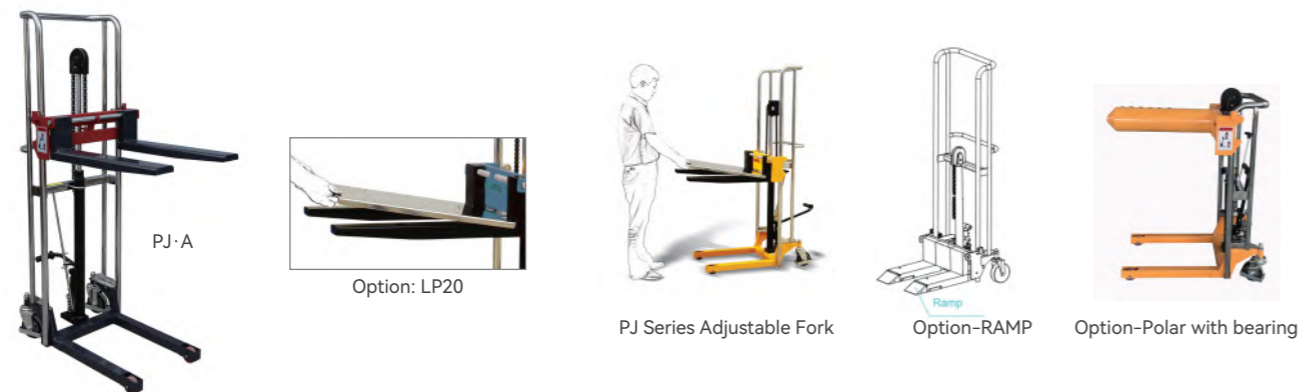

PJ-A

Option: LP20

PJ Series Adjustable Fork

Option-RAMP

Option-Polar with bearing

Model (Adjustable Fork)		PJ2085A	PJ2120A	PJ4085A	PJ4120A	PJ4150A
Capacity	(kg)	200	200	400	400	400
Max. Fork Height	(mm)	850	1200	850	1200	1500
Min. Fork Height	(mm)	85	85	85	85	85
Fork Length	(mm)	600	600	650	650	650
Adjustable Fork Width	(mm)	215-500	215-500	235-500	235-500	235-500
Load Roller	(mm)	Ø75	Ø75	Ø75	Ø75	Ø75
Steering Wheel	(mm)	Ø125	Ø125	Ø125	Ø125	Ø125
Pump Strokes to Max. Height		19	26	35	50	63
Overall Height	(mm)	1080	1435	1060	1410	1710
Overall Width	(mm)	560	560	590	590	590
Overall Length	(mm)	1000	960	1040	1040	1040
Net Weight	(kg)	58	65	75	81	85
Option Platform		LP10	LP10	LP20	LP20	LP20

Self Lifting Stacker YZTS series

- ◆ Semi electric type self lifting stacker, the lifting and lowering speed is adjustable, according to the users' needs.
- ◆ Steering chain auxiliary device.
- ◆ Over discharge protection, extending battery life.
- ◆ Sealed batteries free of maintenance, safe operation and no pollution.
- ◆ Explosion-proof valve design, down more stable and reliable.
- ◆ 700kg model adds the design of the armrest to facilitate the lifting of the cargo.
- ◆ Add the design of the guide rail, makes pushing and pulling the goods more labor-saving and convenient.

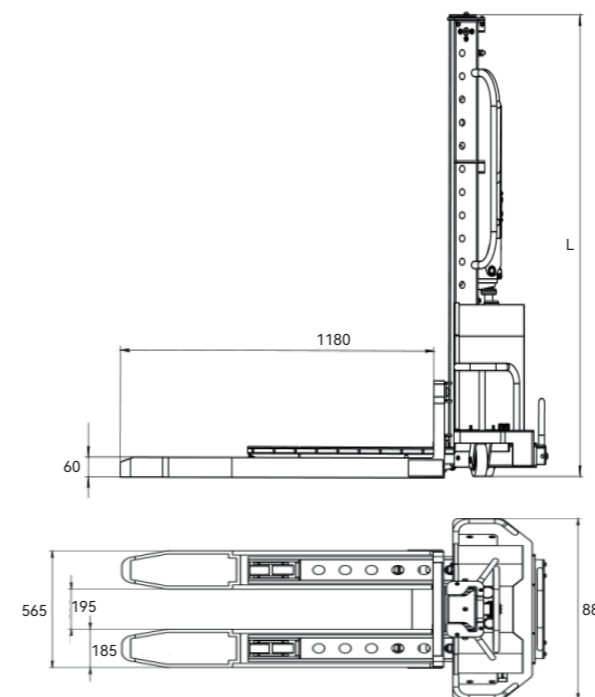

Model		YZTS05A	YZTS05B	YZTS05C	YZTS05D	YZTS05F	YZTS07A	YZTS07B	YZTS07C
Max. Load Capacity	(kg)			500				700	
Load Center	(mm)			400				400	
Max. Lifting Height	(mm)	800	900	1100	1300	1500	1100	1300	1500
Lifting Speed (with/without load)	(mm/s)			135/140				135/140	
Lowered Speed (with/without load)	(mm/s)			145/140				145/140	
Overall Length of Frame	(mm)			1558				1558	
Overall Width of Frame	(mm)			880				880	
Mast Lowered Height	(mm)	1130	1230	1430	1630	1830	1430	1630	1830
Max. Height (mast lifted with backrest)	(mm)			2880				2880	
Wheelbase	(mm)			726				726	
Fork Length	(mm)			1180				1180	
Fork Width (outside)	(mm)			565/626				565/626	
Fork Thickness	(mm)			60				60	
Width of Theoretical Min. Aisle for Right-Angle Stacking (1200x1000mm)	(mm)			1200				1200	
Min Ground Clearance	(mm)			20				20	
Fork Lowered Height	(mm)			90				90	
Min. Turning Radius	(mm)			100				100	
Front Wheel	(mm)			Ø80×50				Ø80×50	
Rated Output	(kw)			0.8				0.8	
Voltage	(V)			12				12	
Battery Capacity	(AH)			45				45	
Weight (with Battery)	(kg)	228	231	238	245	252	251	261	271